

PATENT EXAMINATION BOARD

28.

PRACTICAL LEGAL PROBLEMS: 2010

PAPER 1

Date: 13 July 2010
Time: 09h00 – 12h00
Duration: 3 hours
Examiner: H R Moubray (Tel: 012 676 1025)
Moderator: Advocate Cedric Puckrin
Total marks: 100

In answering this paper (3 pages), candidates are required to give reasons for their answer. The marks depend more on the REASONING DISPLAYED and the POINTS SELECTED FOR DISCUSSION than upon the particular conclusions reached. Marks will be given if appropriate for any relevant points of interpretation, whether dealt with in a short separate section or in the body of the answer. Candidates should not spend time on writing an introduction or a formal précis of the facts in the question or in the documents referred to nor in discussing matter irrelevant to the issues.

Additional material supplied:

Patent A (4 pages)

Document B (3 pages)

Sketch X (1 page)

Your client, who is a manufacturer of electrical accessories, writes:

"We are expecting an SABS requirement that plug and socket connectors must have a safety device so as to make it difficult or impossible to effect an improper connection with a line (current-carrying) socket either accidentally or as the result of tampering by children which might lead to serious shocks.

Some plug and socket connector switches are already provided with a movable insulating shutter which normally overlies the line sockets but which is moved away to expose them upon insertion of an appropriate three-pin plug.

There are only two devices of this kind of which I am aware and both are complicated constructions. In one of them the shutter mechanism is mounted on the base of the switch immediately over the line sockets in the base and this is marked 'Patent A'. A much older construction is shown by the drawing and description herewith (Document B).

One of our employees has just devised a very simple form of shutter mechanism which is shown diagrammatically in Sketch X and before putting this on the market I should like to know whether we are likely to run into any difficulties from patent A.

As will be seen from Sketch X the whole of my shutter mechanism is mounted inside the removable cover of the switch as shown in Fig. 1. Fig. 2 is a sectional side elevation.

The base carrying the sockets and switch mechanism is not shown. The cover 1 has the usual holes L1, L2 and E corresponding with the position of the sockets in the base and a hole 2 for the switch lever which is pivoted in the base. Mounted inside and spaced from the rear face of the cover is a fixed guide plate 3 of insulating material having holes 4 and 5, corresponding with the holes L1 and L2 in the cover, and also a central upright slot 6. A movable insulating shutter 7 is mounted to slide up and down between the inside of the cover 1 and the fixed guide plate 3 and normally lies between the holes L1 and L2 in the cover and the holes 4 and 5 in the plate 3. Standing up from the middle of the shutter is an operating rod 8 terminating in a cam-shaped head 9 which lies behind the hole E so as to be encountered and thrust down by the earth pin of the plug. The head 9 moves up and down in the guide slot 6 and return springs 10 (indicated only

diagrammatically) maintain the shutter in the normal closed position shown in the sketch. When an appropriate three-pin plug is inserted, the earth pin (which is longer than the line pins) engages the cam 9 thus pushing the shutter down to expose the holes 4 and 5 in the guide plate 3 to allow the line pins of the plug to engage the line sockets in the base.

I intend to sell the covers with the shutter mechanisms alone so that purchasers can replace existing conventional covers with the new safety covers. I will also sell complete switches with the new covers."

Patent A is in force and Document B represents a construction of plug and socket connectors available to the public before the priority date of the patent.

Prepare a memorandum as the basis for advice to your client on:

- (1) the possibility of your client infringing patent A, and (40 marks)
- (2) the validity of patent A. (40 marks)

Subsequently to advising your client on infringement and validity your client consults you and advises that the shutter mechanism shown in sketch X was invented by one of his engineers who has subsequently resigned and filed a patent application for the shutter mechanism. Your client received a letter from the engineer threatening your client with patent infringement proceedings should your client manufacture the shutter mechanism.

- (3) Prepare a further concise reasoned memorandum to your client advising it what to do.

(20 marks)

SKETCH X
(1 Sheet)

FIG. 1.

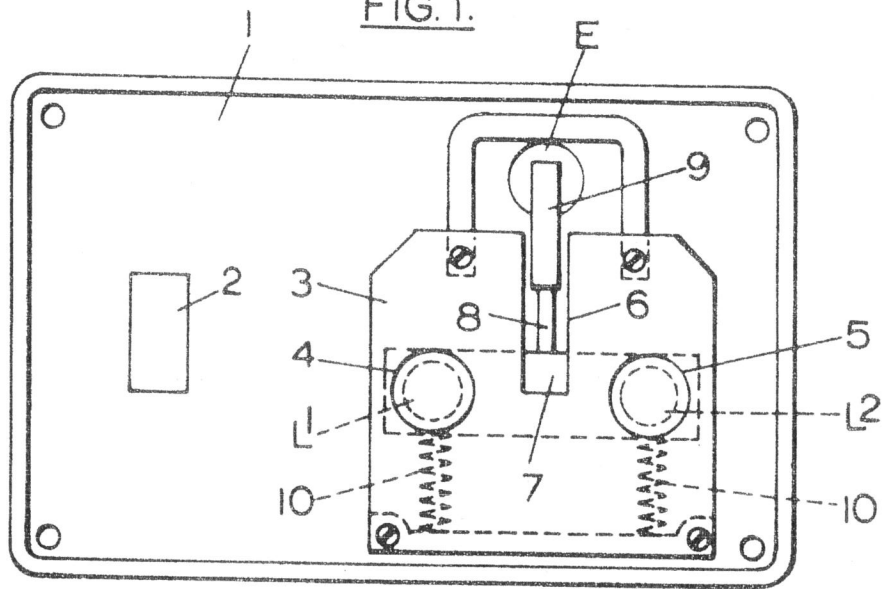
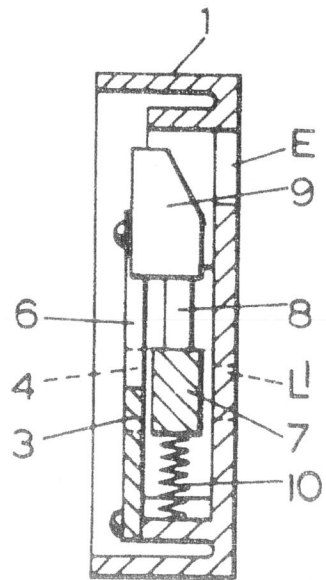

FIG. 2.



PATENT A

IMPROVEMENTS IN ELECTRIC PLUG AND SOCKET CONNECTORS

This invention relates to plug and socket connectors of the three-pin type in which the line and earthing sockets are usually enclosed in a block of ceramic or like material, the cover of which has holes corresponding to the sockets through which the pins are passed to make contact with the sockets.

5

The object of this invention is to provide a safety socket device whereby when the plug is removed the openings to the line sockets are closed and when the plug is inserted the sockets are automatically opened.

10 According to the invention a plug and socket connector of the type described is provided with a shutter which is adapted normally to overlie the line sockets, to prevent access thereto, and means associated with the shutter is adapted to cooperate with the plug so that upon insertion thereof the shutter is moved to expose the line sockets and permit entrance of the plug.

15

The above and other features of the invention will be better understood by reference to the accompanying drawings in which:

20 Fig. 1 is a front view of the socket part of a plug and socket connector switch with part of the cover broken away showing the shutter in the normal position.

Fig. 2 is a similar view showing the shutter in the operated position with the plug pins in position in the sockets.

25 Fig. 3 and 4 are perspective views of the lever and shutter of the mechanism shown in Figs. 1 and 2.

Fig. 4 is a cross-sectional view showing the pivot pins of the lever and shutter,

Fig. 5 is a side view of a typical plug suitable for use with the socket.

As shown in the drawing the socket part of the connector comprises a base 1 and
30 a removable cover 2 through which a switch lever 3 projects. The base 1 has two
line sockets L1 and L2 and an earth socket E and it will be understood that the
cover 2 is provided with holes corresponding with the position of these sockets.

Pivoted at 4 so as to move in a plane above the ends of the sockets is a shutter 5
having flat wings 5A and 5B adapted when in the position shown in Fig. 1 to cover
35 the line sockets L1 and L2. The upper face of the shutter is thinned away at 6
leaving a projecting portion 7 forming a slot 8 for the end of an operating lever 9 as
clearly shown in Figs. 3 and 4.

The operating lever 9 is pivoted at 10 and comprises a second arm 11 which in
40 normal position partly overlies the earth socket E and has a chamfered face 12 for
co-operation with the earth pin of the plug. As indicated in the sectional view Fig. 5
the shutter 5 is provided with a return spring 13 and the lever 9 is provided with a
return spring 14 which springs tend to hold the parts in the normal position shown
in Fig. 1.

45 Fig. 6 illustrates a typical form of plug of the three-pin type, for use with the socket,
the earth pin 15 being slightly longer than the line pins 16 so that insertion of the
earth pin in the hole of the cover brings its end into engagement with the
chamfered face 12 of the arm 11. Pressure on the plug forces the arm aside to
50 move the lever 9 into the position shown in Fig. 2 causing the shutter 5 to swing
about its pivot so that the wings 5A and 5B uncover the line sockets and allow free
entrance of the plug pins to the sockets. When the plug is withdrawn the shutter
and lever are returned to normal position by the return springs.

55 What I claim is:

1. A plug and socket connector of the three-pin type wherein a movable shutter is provided in the socket part of the connector which shutter is adapted normally to overlie the line sockets, to prevent access thereto, and means associated with the shutter is adapted to co-operate with the plug in such manner that upon insertion

60 thereof the shutter is moved to expose the line sockets and permit entrance of the plug.

2. A plug and socket connector according to claim 1 wherein the means is adapted to be moved by the earth pin of the plug.

65

3. A plug and socket connector according to claim 1 or 2 wherein the shutter is pivotally mounted on the socket part of the connector and the means comprises a lever associated with the shutter.

70

4. A plug and socket connector according to claim 1, 2 or 3 wherein the means normally overlies the earth socket, at least in part, and is chamfered for actuating engagement by the earth pin of the plug.

75

5. A plug and socket connector according to any of the preceding claims wherein the shutter is spring-actuated so as normally to overlie the line sockets.

6. A plug and socket connector constructed and arranged substantially as herein described with reference to and as illustrated in the accompanying drawings.

PATENT A
(1 Sheet)

FIG. 1.

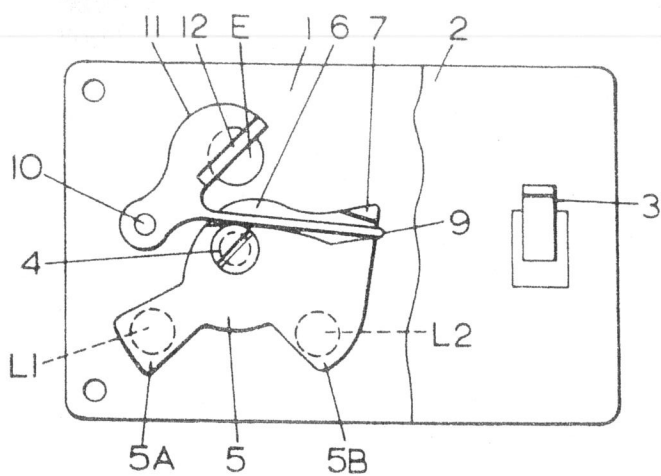

FIG. 3.

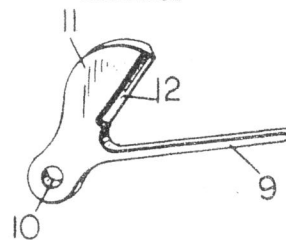

FIG. 2.

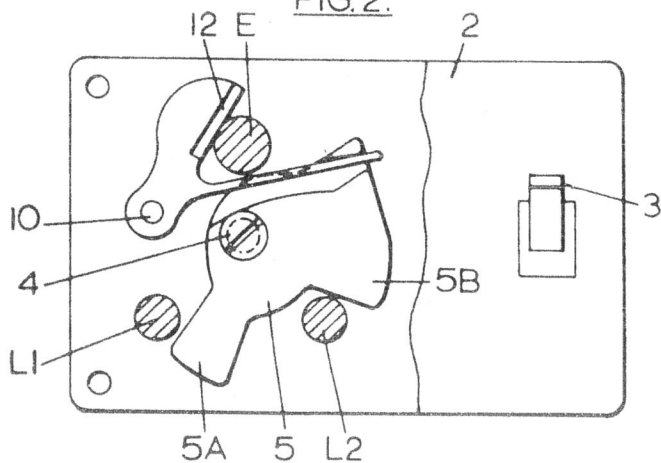

FIG. 4.

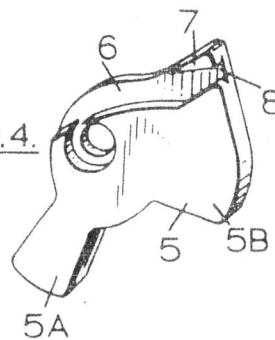

FIG. 6.

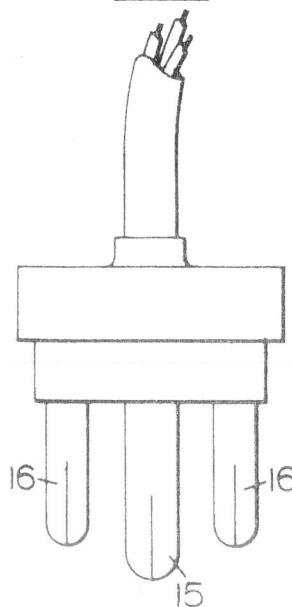
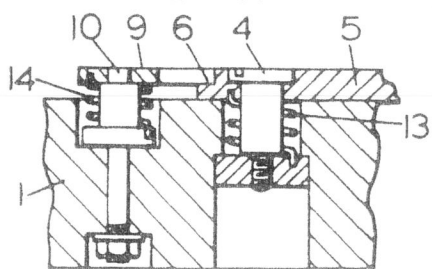

FIG. 5.



DOCUMENT B

DESCRIPTION OF PRIOR ART ELECTRICAL PLUG AND SOCKET

5

CONNECTORS

10

Fig. 1 is a sectional side elevation of a cover of a switch socket, the parts occupying the positions they take up when the socket is not in use. Fig. 2 is an exploded view of the components of the shutter mechanism and Fig. 3 is a view similar to Fig. 1 showing the position which the various elements take up when a correct plug is inserted.

The socket comprises a base, not shown, housing the actual socket members, usually spring metal tubes, and a cover 1 of insulating material secured to the base, like a lid, by screws.

15

The cover has three holes in the usual formation, the two upper holes being for the reception of the current-carrying plug pins and a lower single hole, which is somewhat larger, serving for the earth pin. The moving components of the shutter mechanism are mounted on a fixed retaining plate 2 which is secured to the cover 1 by the screws 3. The plate 2 has holes 4, 5 and 6 arranged in similar formation to those of the cover but sufficiently large to clear all the plug pins with an ample margin. It has also a central slot 7 which serves as a guide for the moving shutter components.

20

25

The upper holes in the cover, for the current-carrying pins, are normally covered by an insulating shutter 8 which is of the shape best shown by Fig. 2 and is provided with two bevelled or inclined surfaces 9 and 10 to be encountered by the current-carrying pins. The effect is that when the plug pins engage the inclined surfaces the shutter 8 is moved upwards against the action of the springs 11 which encircle the cylindrical projections 12 and bear against the inside of the rim of the cover 1. An auxiliary shutter 13 also of insulating material is in the form of a flat plate and has three holes corresponding in size and location to those of the plug pins. The shutter 13 is guided so as to be capable of sliding up and down and if unconstrained follows the movements of the outer shutter 8 owing to a yielding connection provided by the latch member 14. This is of the shape shown

30

and is provided with a spring tongue 15 adapted to engage in a small square hole
35 16 in the shutter 13. The latch member is adapted to slide in the slot 7 in the
retaining plate 2 and serves to guide and control the movement of both the outer
shutter 8 and the inner shutter 13. When a correct three-pin plug such as 17 is
inserted in the socket, the earth pin 18 engages in the corresponding hole 19 in
the shutter 13 and prevents the shutter 13 from moving. Hence, when the plug is
40 pushed further in and the current-carrying pins engage the surfaces 9 and 10 of
the outer shutter 8, the yielding connection between the two shutters provided by
the latch member 14 permits the shutter 8 to move upwards and uncover the
socket tubes in the base.

If, however, a two-pin plug, or some other member, is inserted into one or both of
45 the upper holes, although the outer shutter 8 can move upwards there is nothing
to restrain the inner shutter 13 which also moves upwards with the shutter 8
under the influence of the latch member 14 and thus covers the holes 4 and 5 in
the retaining plate 2. The wrong plug or other body, therefore, cannot be pushed
home sufficiently far to make contact. It will be noted that in ordinary operation,
50 with a correct three-pin plug, no movement of the auxiliary shutter 13 takes place
and the earth pin does not produce any movement of any part but merely serves
to hold the auxiliary shutter against being entrained in the movement of the main
shutter.

DOCUMENT B
(1 Sheet)

FIG. 1

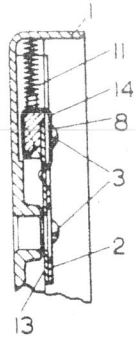

FIG. 2

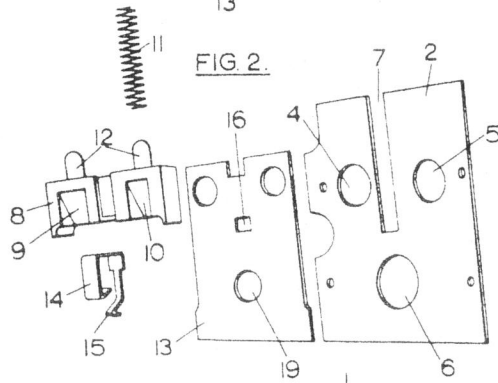

FIG. 3

